

## INSTALLATION, OPERATION AND MAINTENANCE MANUAL

Limit Switch Box with 2 Inductive Detectors  
“P + F” NCB2-V3-N0 for Rotary  
Pneumatic Actuators



Ref. GENE BRE: 5987 08

## Installation, operation and maintenance instructions

<b>1. Product Description</b>	3
<b>2. Storage</b>	3
<b>3. Component Parts</b>	4
<b>4. Installation instructions</b>	4
4.1 Preparation	4
4.2 Installation on the actuator	5
4.3 Electrical connection	5
4.4 Adjustment of Cams	6
<b>5. Operational instructions</b>	6
<b>6. Maintenance operations</b>	6
<b>7. Reparation instructions</b>	7
<b>8. Hygiene and Safety Instructions</b>	7

## 1. Product Description.

The limit switch box is used to indicate the position of the valve, open or closed of automated valves and also hand operated valves.

- These boxes are manufactures in accordance with NAMUR (VDI/VDE 3845).
- Ingress Protection IP 67 according to IEC 60509 standard.
- Easy setting without tool based on spring loaded splinted cam.
- Position indicator of great visibility Open / Closed.
- Dual cable entries M20 x 1,5.
- 8 points and enough strips for electrical connection.
- Bracket with Epoxy Coated painted (Namur 30x80 H=30).
- 2 Inductive Sensors  II 1G EEx ia IIC T6.

## 2. Storage

During storage it is recommended to keep the product in the included protective wrapping to avoid damages or dirt accumulation. The wrap must not be removed until element is to be installed. As much as possible, it must be stored in a dry and clean environment.



**Transport and storage of these devices must be done in their original wrapping.**

### VISUAL INSPECTION

Check whether during transport, unloading and placement, devices have suffered no damages.

### MECHANICAL INSPECTION

Check whether all mobile parts of the different devices, as well as the screws and other elements, are accomplishing their purpose.



**If you notice any kind of anomaly during reception of the goods, contact immediately with GENE BRE in order to determine the possible responsibilities on the issue and make the devices fully operational.**

## IMPORTANT NOTE:

Before installing and/or manipulating these pneumatical elements, **READ CAREFULLY** these instructions for use and **OBSERVE** all contained information. If you fail to understand any of their content, please **contact GENEBRE, S.A.**



**User is responsible for the safe use of these devices, as established in present instructions for use and in the specific technical documentation of the device.**

### 3. Component Parts

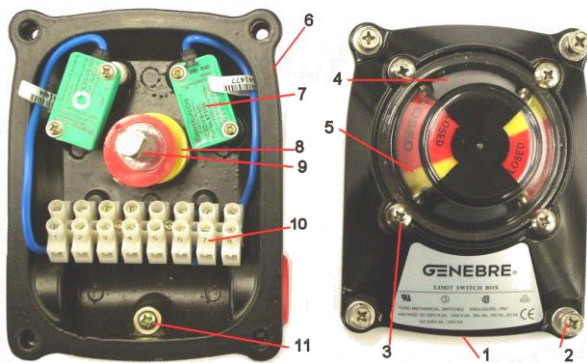

Nº	Name	Spare Part Code
1	Box Cover	-----
2	Cover Bolts	-----
3	Indicator Bolts	----
4	Indicator Cover	C5987
5	Indicator	C15987
6	Box	-----
7	Detectors	S5987 08
8	Cam	----
9	Shaft	-----
10	Terminal Strip	-----
11	Earth Lug	-----

### 4. Installation instructions

#### 4.1) Preparation

Remove any material remains of the element wrapping.  
Prepare a clean working area.  
Plan beforehand enough space for future maintenance operations.

It is recommended to perform this task under qualified professional surveillance.

## 4.2) Installation on the actuator

Design according NAMUR VDI / VDE 3845.

The limit switch's support is designed to be mounted on actuators with a shaft height of H=30, as well as fixing holes at 80 mm according to Namur standard.

Make sure that both actuator and limit switch are in closed position.

Mount the limit switch by means of the four screws and washers. Apply "cross method" for tightening.

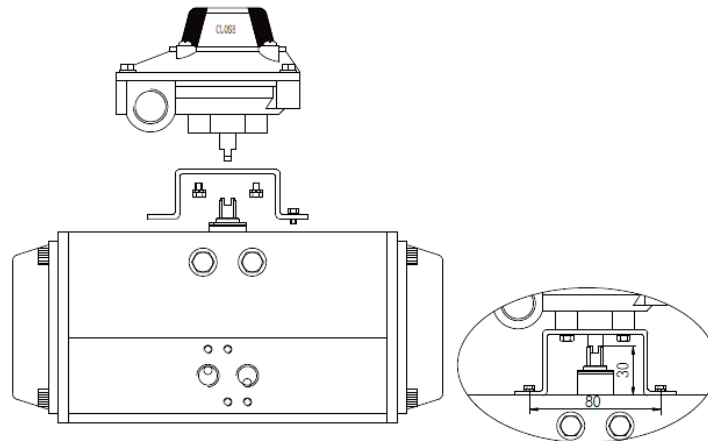

## 4.3) Electrical connection

Be extremely cautious before powering the equipment and take into account the power tension for which it is indicated. Wiring must be done with a cable clamp.

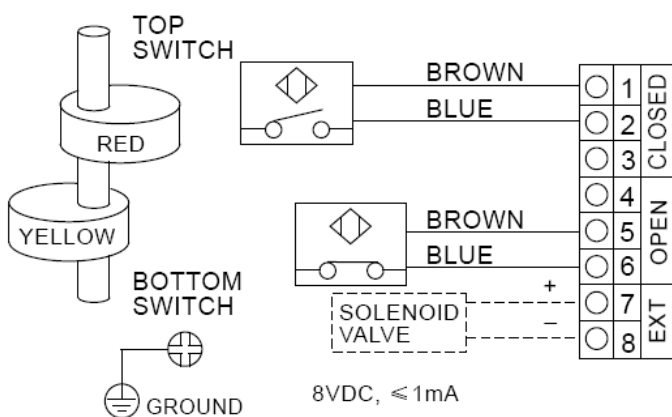

SENSORS FEATURES	
Sensor Inductive Model	"P+F" NCB2 – V3 – N0
Ex Identification	<b>II 1G EEx ia IIC T6</b>
Switching element function	NAMUR NC.
Detect Distance	2 mm
Installation	embeddable
Output Polarity	NAMUR
Assured operating Distance	0 ..... 1,62 mm
Nominal Voltage	8 V
Switching frequency	0 .... 2000 Hz
Hysteresis	Tip. 5% / typ. 5%
Current consumption	Sensor not detected ≥ 3 mA Sensor detected ≤ 1 mA
Indication of the switching state	Yellow LED
Housing Material	PBT
IP Ratings	IP 67
Working Temperature	-25 / + 100 °C

## 4.4) Adjustment of Cams

The unit is already adjusted in the factory at 0° and 90°, however it could be necessary a later adjustment in Open and/or Close position:

1. Loosen limit switch box cover screws (part.2) and remove cover (part.1).
2. Rotate actuator to full counterclockwise position. Valve is on fully open position.
3. Lift up bottom cam (part.8) and turn until switch is activated and then release. Engage cam back onto the splined retainer. Spring will maintain cam engagement.
4. Rotate actuator to full clockwise position. Valve is on fully closed position.
5. Push down top cam (part.8) and turn until switch is activated and then release. Engage cam back onto the splined retainer. Spring will maintain cam engagement.
6. Place cover (part.1) on limit switch box and tighten the screws (part.2).

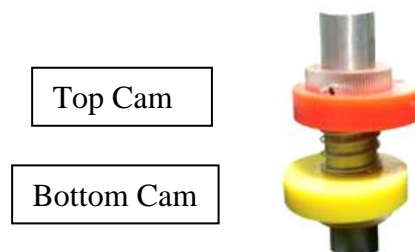

## 5. Operational instructions

Before starting the equipment, you have to read the Technical Specifications and never exceed the Power limit values.

## 6. Maintenance operations

Inspect the components of the limit switch box for wear or damage and replace where necessary.

## 7. Reparation instructions

Available spare parts see point 3.

Before starting to repair it, disconnect the limit switch box.



¡Use only components/spare parts original or recommended by GENE BRE, S.A

## 8. Hygiene and Safety Instructions:

When operating any kind of element, you must follow the security instructions and it is recommended to use personal protection gadgets:

- 1) Protect your eyes.
- 2) Wear gloves and appropriate working clothes.
- 3) Wear safety footwear.
- 4) Wear a helmet.
- 5) Have running water at hand.