

INSTALLATION, OPERATION AND MAINTENANCE MANUAL

Manual Gear Operator



GENEBRE Ref.: 5975-5976-5977-5978

Installation, operation and maintenance instructions

1) ASSEMBLY DRAWING	3
1.1) PART LIST.....	4
2) STORAGE.....	4
3) INSTALLATION INSTRUCTIONS	4
3.1) PREPARATION	4
3.2) ASSEMBLING TO THE VALVE	4
3.3) ADJUSTMENT OF THE REGULATION SCREWS.....	4
4) OPERATION INSTRUCTIONS.....	5
4.1) MANUAL OPERATION	5
4.2) TORQUES	6
4.3) CONNECTIONS DIMENSIONS.....	6
5) MAINTENANCE OPERATIONS	7
6) HYGIENE AND SAFETY INSTRUCTIONS	7

1. Assembly drawing

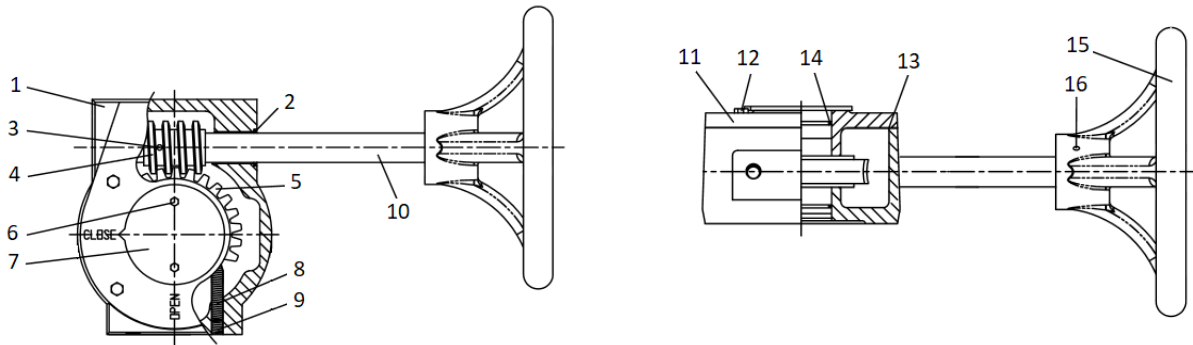

1.1 Parts list

Nº	Name	Material	Surface Treatment
1	HOUSING	CAST IRON	PAINTED
2	SEALING RING	NBR	-----
3	PIN	STEEL	-----
4	WORM	STEEL	-----
5	WORM GEAR	DUCTILE IRON	-----
6	SCREW	STEEL	ZINC PLATED
7	INDICATOR	STEEL	ZINC PLATED
8	REGULATION SCREW	STEEL	BROWNING
9	SCREW	STEEL	BROWNING
10	STEM	STEEL	ZINC PLATED
11	HOUSING COVER	CAST IRON	PAINTED
12	SCREW	STEEL	ZINC PLATED
13	GASKET	PAPER WITH GRAPHITE	-----
14	O'RING	NBR	-----
15	HANDWHEEL	CAST IRON	PAINTED
16	PIN	STEEL	-----

2. Storage

During storage it is recommended to keep the Gear Operator in the same position as delivered, with the included protective wrapping to avoid damages or dirt accumulation. The wrap must not be removed until the operator is to be installed. As far as possible, store in a dry and clean environment. If you expect to have the product stored for a long period of time, apply anti rust oil over machined areas. Repeat every 6 months if necessary.

3. Installation instructions

3.1 Preparation

Remove any wrapping material from the product.

The Gear Operator is delivered in the closed position.

It is recommended to put the *Handwheel* (part. 15) together with the *Shaft* (part. 10) before assembling the Gear Operator to the valve. The included *Pin* (part. 16) will be used for this purpose.

3.2 Assembling to the valve

1- Check if the bolt circle on top flange and stem dimensions of the valve coincide with the bolt circle and square hole of the gear operator, respectively (connection according to ISO 5211 standard).

2- Make sure that both valve and gear operator are in fully closed position.

3- Mount the gear box with its shaft perpendicular to the valve (or pipeline) by means of the attached four screws and washers. Apply "cross method" for tightening.

4- The assembly is ready for adjustment (see below).

3.3 Adjustment of the regulation screws

The unit is already adjusted in the factory at 0° and 90°, however it could be necessary a later adjustment in Open and/or Close position of the valve. The range of adjustment is +/- 10° for both positions.

Before regulating the *Screws* (part. 8) must remove both *Stud Bolt* (part. 9) to provide access.

The procedure simply consists on checking that the valve is fully open in Open position and fully closed in Close position. Adjust the Regulating Screws as much as necessary (between the range of adjustment) and put the screws (part. 9) to lock the stops.

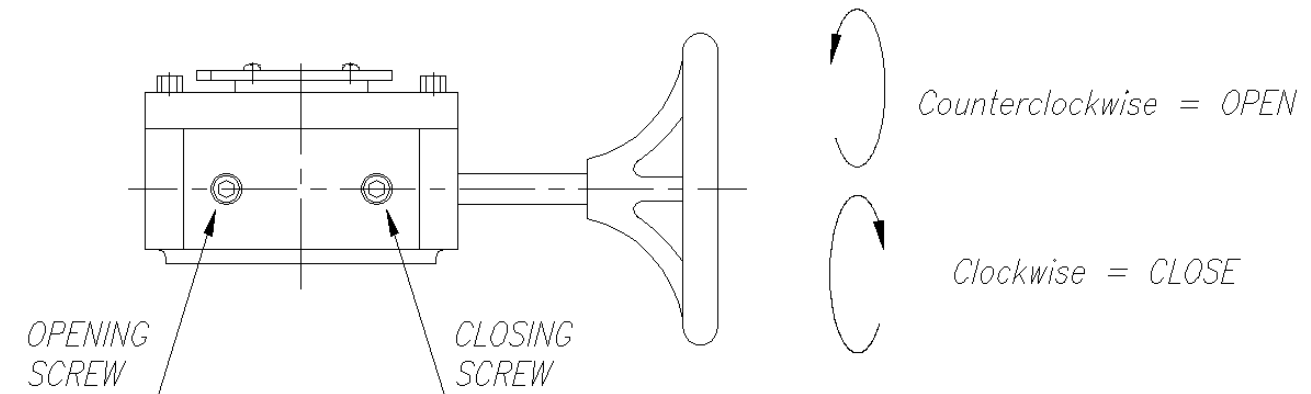

REMARKS:

- degrease completely the contact surface between valve and gear box.
- it could be necessary the addition of square adapters for a proper coupling.
- in butterfly valves it is recommended assembling and adjustment with the valve closed.
- however, in ball valves it is recommended assembling and adjustment with the valve open.
- gear box can be installed in any position, however, in outdoors it is recommended to be installed vertical (with handwheel parallel to the floor) to avoid water inside.

4. Operation instructions

4.1 Manual operation

The gear operator provides the valve a smooth and slow operation, reduces the effort required to open or close especially on large valves.

It prevents water hammer by opening or closing fast on the valve.

The gear boxes are manually operated by handwheel. Turn clockwise for closing or turn counterclockwise for opening the valve. The position is shown by the indicator plate (part.7) on top of the gear box.

In case the valve can't completely achieve Open or Close positions, first try to find out the reason of malfunction to prevent further damage. Do not attempt to force the handwheel beyond the stop limits.

For the valves operated with gear box, the quantity of turns to be done for a complete operation cycle 90° will be conditioned by the transmission ratio of the gear box. See table below:

Ref.	Transfer Ratio	Nº gear turns (90°)
5975	24 : 1	6
5976	30 : 1	7.5
5977	50 : 1	12.5
5977A	50 : 1	12.5
5977B	50 : 1	12.5
5978	80 : 1	20
5978A	80 : 1	20

4.2 Torques

The maximum allowable output torque of the gear operator is as listed below:

Ref.	Torque (Nm)
5975	300
5976	750
5977	1200
5977A	1200
5977B	1200
5978	2000
5978A	2000

It is recommended not to overpass the 90% of the maximum allowable torque for a longer life of the product.

4.3 Connections Dimensions

The gear operator are designed for mounting on the valve according to ISO 5211 standard.

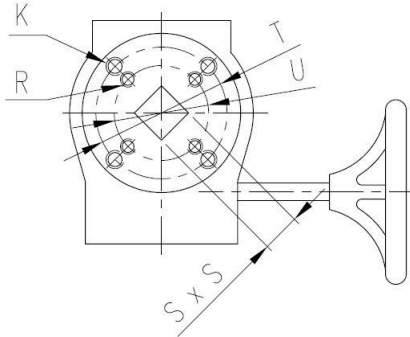

Ref.	Dimensions (mm)				
	S x S	T	U	K	R
5975	17 X 17	F 07	F 05	M 8	M 6
5976	22 X 22	F 10	F 07	M 10	M 8
5977	22 X 22	F 10	-	M 10	-
5977A	22 X 22	F 12	-	M 12	-
5977B	27 X 27	F 14	-	M 16	-
5978	27 X 27	F 14	-	M 16	-
5978A	36 X 36	F 14	-	M 16	-

5. Maintenance operations

Gear operators are designed so that they do not need any lubrication and/or periodical maintenance during their life cycle. However, periodical checks will be useful to extend the service life of the product. Verify all locks and threaded ends to check if they are loose or with rust. Tighten them if necessary.

6. Hygiene and Safety Instructions

6.1) Fluids that go through the valve can be corrosive, toxic, flammable or pollutant. When operating valves, you must follow the security instructions and it is recommended to use personal protection gadgets:

- 1) Protect your eyes.
- 2) Wear gloves and appropriate working clothes.
- 3) Wear safety footwear.
- 4) Wear a helmet.
- 5) Have running water at hand.
- 6) To operate flammable fluids, make sure you have an extinguisher at hand.

6.2) Before removing a valve from a pipe, check always if the line is completely drained and depressurized.