

INSTALLATION, OPERATION AND MAINTENANCE MANUAL

Gate Valve with rubber seal



Ref. GENE BRE: 2102 – 2102P

Installation, operation and maintenance instructions

1) PRODUCT DESCRIPTION	3
2) ASSEMBLY DRAWING	3
2.1) PARTS LIST.....	4
3) TRANSPORT AND STORAGE CONDITIONS	4
4) INSTALLATION INSTRUCTIONS	5
4.1) PREPARATION	5
4.2) INSTALLATION OF VALVES WITH FLANGED ENDS	5
5) OPERATION INSTRUCTIONS	6
5.1) USAGE	6
5.2) HANDWHEEL OPERATION	6
5.3) T-HANDLE OPERATION	6
6) MAINTENANCE OPERATIONS	7
7) REPAIR INSTRUCTIONS	7
8) TORQUES	7
8.1) TORQUE TO CLOSE THE VALVE (N·M)	8
9) HYGIENE AND SAFETY INSTRUCTIONS:	8

1) Product description

Genebre, S.A. offers a wide range of valves designed and assembled to handle and drive fluids in industrial procedures.

The compatibility of materials used to build the valves (see technical specifications) and the application of valves to the different industrial processes is at user's risk. Valves will have an optimal behaviour when working conditions do not exceed pressure and temperature limits (pressure curve) for which they have been designed. Please, refer to the product datasheet.

Art. 2102 and 2102P: Ductile Iron Wedge Gate Valve NRS (non-rising stem) with EPDM seal.

2) Assembly drawing

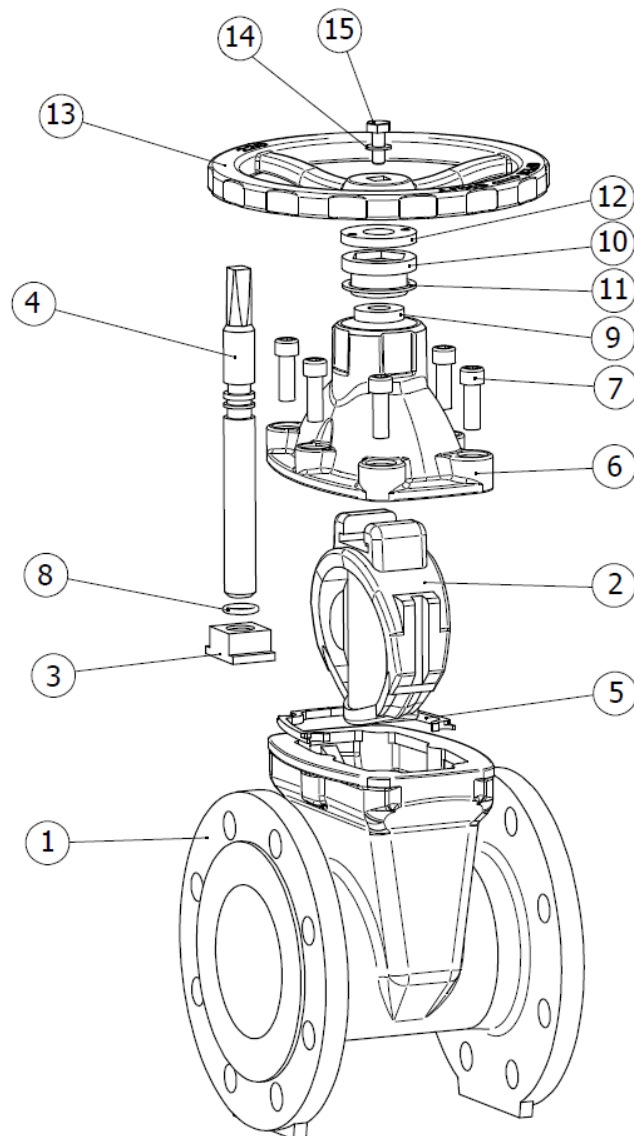

2.1) Parts list

Nº	Denominación / Name	Material	Acabado Superficial / Surface Treatment
1	Cuerpo / Body	Fundición Nodular / Ductile Iron EN-GJS-500	Pintura epoxi / Epoxy coating
2	Compuerta / Wedge Body	Fundición Nodular / Ductile Iron EN-GJS-400 + EPDM	-----
3	Tuerca del Eje / Stem Nut	Latón / Brass	-----
4	Eje / Stem	AISI 410	-----
5	Junta Cuerpo / Body Gasket	EPDM	-----
6	Tapa / Bonnet	Fundición Nodular / Ductile Iron EN-GJS-500	Pintura epoxi / Epoxy coating
7	Tornillo / Screw	Acero Carbono / Carbon Steel	-----
8	Tórica / O'ring	EPDM	-----
9	Separador / Locating Ring	Acero Inoxidable / Stainless Steel	-----
10	Tuerca prensaestopas / Packing Nut	Latón / Brass	-----
11	Arandela / Washer	Nylon	-----
12	Tapón anti-polvo / Anti-Dust ring	Plástico ABS / ABS Plastic	-----
13	Volante / Handwheel	Acero Carbono / Carbon Steel	Pintura epoxi / Epoxy coating
14	Arandela / Washer	Acero Carbono / Carbon Steel	Cincado / Zinc PLated
15	Tornillo / Screw	Acero Carbono / Carbon Steel	Cincado / Zinc PLated

3) Transport and Storage conditions



Transport and storage of this kind of products must be done keeping them in their original package!

VISUAL INSPECTION

Check whether during transport, unloading and placement the products have suffered damages.

During storage it is recommended to keep them into the included protective wrapping to avoid damages or dirt accumulation in the inside part of the valve. The wrap must not be removed until valve is to be installed.

Valves must be stored in a dry and clean environment.



If you notice any kind of anomaly during reception of the goods, contact immediately with GENE BRE in order to determine the possible responsibilities on the issue.

IMPORTANT NOTE:

Before installing and/or manipulating these elements, READ CAREFULLY these instructions for use and OBSERVE all contained information. If you fail to understand any of their content, please contact GENE BRE, S.A.

4) Installation instructions

4.1) Preparation

Remove any material remains of the valve wrapping.

Serious problems may arise with the installation of a valve in a dirty pipe.

Make sure the pipe is not dirty and doesn't have welding particles, for example, before installing it. This may cause irreparable damages in the valve when the equipment is started → *prepare a clean working area.*

Plan beforehand enough space for future maintenance operations.

Control the correct performance of the valve by turning the handwheel both sides (close and open) and observing if the disc or needle slides correctly. If this is not the case, check if there are foreign particles inside the valve and repeat the whole operation.

In case of vibrations in the pipe it is strongly recommended to mount anti-vibration elements to absorb them. Otherwise, the life of the product could be drastically reduced.

4.2) Installation of valves with flanged ends

Make sure the pipe's and edges flanges of the valve are clean.

Use the corresponding screws in all of the flanges drill holes.

Place an adequate joint in each end and align it in the centre of the flanges.

Tighten screws evenly and cross-shaped to avoid deformations. To do so, you must not force in any case the pipe to centre the valve; it should take its position smoothly. Last, verify that screws are tightened with the recommended torque for each type of screw.

Make sure the flanges joints are well placed.

After assembling, check the tightness and performance of the valve.

REMARKS:

- ***Gate Valves, ref. 2102, are designed to be assembled between flanges EN 1092 PN16 at a maximum working pressure of 16 bar. At the same time, this valve can be assembled between flanges EN 1092 PN10 in sizes from DN50 until DN150, for assembled between flanges EN 1092 PN10 DN200 to DN300 should be use ref. 2102P.***
- ***Verify good parallelism of the flanges.***
- ***Valve must never be assembled adjacent to an elbow (or any other accessory) in order to avoid turbulences. Minimum distance recommended between elbow and valve is 10 times the pipe diameter (upstream) and 3 times the pipe diameter (downstream), according to CR 13932:2000.***
- ***Any damaged paint/coating during installation must be immediately repaired.***
- ***It is recommended the use of filters in the pipe to make the valves longer life.***

5) Operation instructions

5.1) Usage

Gate valves art. 2102 and 2102P provide a leakproof seal when used adjusted to the pressure and temperature values for which they have been designed.

Seat material for the valve, joints, body, disk and axis have to be fully compatible with the fluid circulating through the valve. Otherwise, valve could be seriously damaged.

This valve is suitable for underground waterworks usage with clean water or neutral liquid up to 80 °C.

Minimum torques required to close the valves are listed in the table *Torque to close the valve*, on paragraph 8.

5.2) Handwheel operation

The valves are designed to be manually operated by handwheel. Turn clockwise for closing or turn counterclockwise for opening the valve.

5.3) T-Handle operation

In case it is necessary to operate the valve with T-Handle, GENE BRE, S.A. can provide stem adapter for this purpose: art. D2102. For more information, please refer to the product datasheet.

6) Maintenance operations

Non-rising stem gate valves are designed so that they do not need any lubrication and/or periodical maintenance during their life cycle.

However, periodical checks explained below will be useful to extend the service life of the valve and reduce installation problems:

- Close the valve –from position completely open to completely closed.
- Verify all locks and threaded ends to check if they are loose or with rust. Tighten them if necessary.
- Inspect the valve and surrounding areas to verify if there is any leakage in the stem or in the flange connections.

7) Repair instructions

These types of valves, due to their assembling specifications are not worth repairing, because most of the times are simply not cost-effective, so we recommend to directly replace them.



Before disassembling the pipe's valve to clean or replace it, make sure that line has been closed and depressurized because a bad operational procedure could cause a serious accident to staff and installation system



Before installing new valve, check if it meets the requirements of the valve being replaced

8) Torques

8.1) Torque to close the valve (N·m)

SIZE	Minimum torque (N·m)
2"	48
2 1/2"	60
3"	60
4"	80
5"	100
6"	120
8"	150
10"	170
12"	200

9) Hygiene and Safety Instructions:

9.1) Fluids that go through the valve can be corrosive, toxic, flammable or pollutant. They can also be found at very high or low temperature. When operating valves, you must follow the security instructions and it is recommended to use personal protection gadgets:

- 1) Protect your eyes.
- 2) Wear gloves and appropriate working clothes.
- 3) Wear safety footwear.
- 4) Wear a helmet.
- 5) Have running water at hand.
- 6) To operate flammable fluids, make sure you have an extinguisher at hand.

9.2) Before removing a valve from a pipe, check always if the line is completely drained and depressurized.

9.3) Any valve being used by toxic services department needs to obtain a cleanliness certificate before being operated.

9.4) Any type of repair or maintenance should be performed in ventilated places.