

INSTALLATION, OPERATION AND MAINTENANCE MANUAL

2 piece full bore ball valve
direct mount, threaded ends



GENEBRE Ref.: 2015 – 2015N

Installation, operation and maintenance instructions

1. Product description.	3
2. Transport and Storage conditions.....	3
3. Exploded drawing.....	4
4. Installation instructions.....	5
4.1) Preparation.....	5
4.2) Assembling.....	5
5. Operating instructions	6
5.1) Usage	6
5.2) Manual operation	7
5.3) Remote operation	7
6. Maintenance instructions	7
6.1) Stem leakage	7
6.2) Body/cap joint leakage.....	8
6.3) Line leakage (through seats).....	8
7. Reparation instructions	8
7.1) Disassembling.....	8
7.2) Reassembling	10
8. Torques table:	11
8.1) Breakaway torques:	11
8.2) Tightening torque for stem nut:	11
9. Hygiene and Safety Instructions:	11

1. Product description

Genebre, S.A. offers a wide range of ball valves (90° turn), designed and assembled to handle and drive fluids in industrial procedures.

The compatibility of materials used to build the valves (see technical specifications) and the application of valves to the different industrial processes is at user's risk. Valves will have an optimal behavior when working conditions do not exceed pressure and temperature limits (pressure curve) for which they have been designed. Please, refer to the product datasheet.

Ref. 2015: Ball valve with threaded ends according to ISO 7/1.

Ref. 2015N: Ball valve with threaded ends according to NPT.

2. Transport and Storage conditions



Transport and storage of this kind of products must be done keeping them in their original package!

VISUAL INSPECTION

Check whether during transport, unloading and placement the products have suffered damages.

Manual valves are provided by default in a open position whereas automated valves usually are offered in a closed position due to the standard NC (normally closed). During storage it is recommended to keep them in this same position, with the included protective wrapping to avoid damages or dirt accumulation in the ball. The wrap must not be removed until valve is to be installed.

Valves must be stored in a dry and clean environment.



If you notice any kind of anomaly during reception of the goods, contact immediately with GENEBRE in order to determine the possible responsibilities on the issue.

IMPORTANT NOTE:

Before installing and/or manipulating these elements, **READ CAREFULLY** these instructions for use and **OBSERVE** all contained information. If you fail to understand any of their content, please **contact GENEBRE, S.A.**



User is responsible for the safe use of these products, according to present instructions for use and specific technical documentation of the device.

3. Exploded drawing

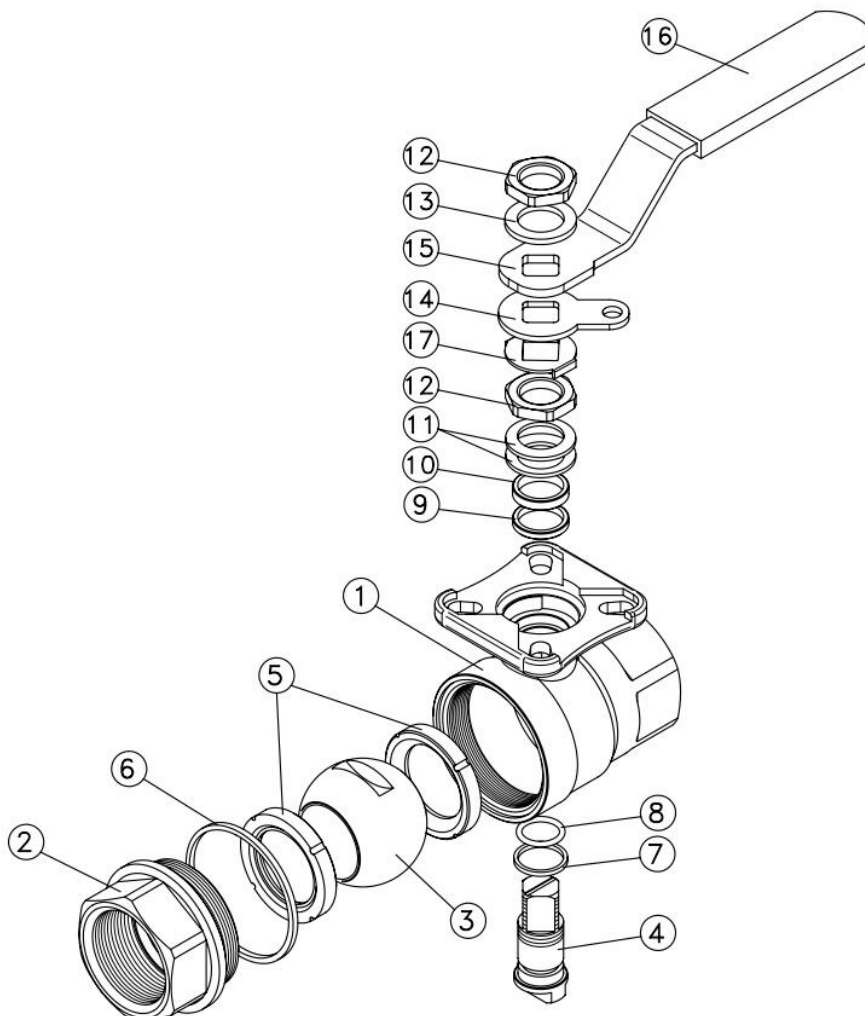

Part num.	Description	Quant.	Material	Replacement (ref.)
1	Body	1	CF8M	----
2	Cap	2	CF8M	----
3	Ball	1	316	2907
4	Stem	1	316	2905
5	Seat	2	PTFE+FV	2822
6	Joint	1	PTFE+FV	2822
7	Friction washer	1	PTFE + graphite	2822
8	O-ring	1	Viton	2822
9	Wrapping	1	PTFE	2822
10	Gland nut	1	304	----
11	Belleville Washer	2	301	----
12	Stem nut	2	304	----
13	Washer	1	304	----
14	Stopper	1	304	----
15	Handle	1	304	----
16	Handle cap	1	Vinyl	----
17	Lock nut	1	304	----

4. Installation instructions

4.1) Preparation

Remove any material remains of the valve wrapping.

Serious problems may arise with the installation of a valve in a dirty pipe.

Make sure the pipe is not dirty and doesn't have welding particles, for example, before installing it. This may cause irreparable damages in the valve when the equipment is started → *prepare a clean working area.*

Plan beforehand enough space for future maintenance operations.

Control correct operation of the valve by turning the handle clockwise and making sure the ball closes the fluid flow. If this is not the case, check if there are foreign particles inside the valve and repeat the whole operation.

In case of vibrations in the pipe it is strongly recommended to mount anti-vibration elements to absorb them. Otherwise, the life of the product could be drastically reduced.

4.2) Assembling

Make sure the valve's pipe and thread end are clean and are compatible one with another (type of thread end) Apply an appropriate sealing in the pipes' thread ends and thread the valve being careful not to excessively tighten the conical threaded ends.

Do not use valve's handle as a lever to thread the valve into the pipe.

To tighten the valve it is recommended to use a spanner or monkey wrench only on the hexagonal area of the valves edges; the torque applied being less than 30 Nm.

IMPORTANT INFORMATION:

Design of this kind of floating ball valves allows us to install them in any position as they are bidirectional, so the direction of fluid flow does not matter.

If possible, it is recommended to install the valve in horizontal position and the stem (handle) upwards.

Valves do not have to support pipe's efforts so it is advisable to anticipate a good alignment and parallelism of such pipe.

Once installed, it is recommended to open and close it a couple of times to verify its good knowledge and to check if there is any obstruction in the ball that prevents it from closing.

It is also recommended to use filters in the pipe to extend lifecycle of the valve.

5. Operating instructions

5.1) Usage

Ball valves provide a leakproof lock when used adjusted to the pressure and temperature values for which they have been designed.

Avoid by all means leaving the valves in partially open position if you are not aware of the pressure drop and flow rate in that position, as the service life of the seat can be reduced and/or it can be damaged due to the floating ball valve.

Any fluid that can be solidified, crystallized or polymerized should not remain in the ball cavity as it is harmful for performance, service life of the valve and it can even render it unusable.

Seats for the valve, joints, body, ball, stem and ends have to be fully compatible with the fluid circulating through the valve. Otherwise, valve could be seriously damaged.

Torques required to operate valves are listed in the table Torques to activate the valves (see Section 8.1).

5.2) Manual operation

When operating the valve you must avoid excessive lateral efforts with the handle. To close it, you must turn the handle 90 degrees clockwise. When the handle is inline with the pipe, valve is open.

In case you need to remove the handle to automate the valve, the *stem* (part 4) has a mechanized linear mark at the front part that allows us to know its current position (opened or closed).

5.3) Remote operation

When automation of the valve is required, GENE BRE S.A. can provide a great variety of pneumatic actuators, electric actuators, electropneumatic and electronic positioners to cap a large range of operations.

6. Maintenance instructions

Frequency, place and process of maintenance will be determined by the user by taking into account usage of the product. However, checks explained below will be useful to extend the service life of the valve and reduce installation problems.

Valves must not remain in open or closed position for a long period of time. It is recommended, if the process allows for it, to operate it for control purposes every six months.

6.1) Stem leakage

Remove the handle or actuator, the *lock nut washer* (part 17) and tighten the nut (part 12) of the stem packing (see *Section 8.2*). If the leak persists, valve should be disassembled to replace the stem washers (part 7, 8, 9).

See reparation instructions.

6.2) Body/Cap joint leakage

Check if the cap (part 2) is tight. If it was loose, tighten it. If leak continues, it is probably due to damage in the body's joint or the locking surface, and it will be necessary to disassemble the valve to repair it.

See reparation instructions.

6.3) Line leakage (through seats).

Check if the valve is in a completely closed position. If this is the case, leak is due to a seat or locking surface being damaged and it will be necessary to disassemble the valve for repairing it.

See reparation instructions.

7. Reparation instructions



Before disassembling the pipe's valve to repair or replace it, make sure that line has been closed and depressurized because a bad operational procedure could cause a serious accident to staff and to the installation system

7.1) Disassembling

You must remove the installation valve to repair it.

Prepare a clean working area and adequate tools to perform mechanical tasks.

a.- Place the valve in a completely CLOSED position.

Remember that the stem has a line in the frontal part to indicate position of the valve:

- parallel to pipe → open valve,
- perpendicular to pipe → closed valve,

- b.- Loosen and remove the cap (part 2). Be careful not to damage the valve surfaces.
- c.- Once the cap is removed (part 2) remove the ball (part 3) being careful not to damage it.
- d.- Remove both seats (part 5) from their corresponding location inside the body and also inside the cap.
- e.- After this, remove the body's *joint* (part 6). Joints should be removed being carefully not to scratch or damage the mechanized surfaces over which they are hermetically sealed.
- f.-To disassemble the *stem* (part 4), remove the following elements:

Name	Art. 2015
Stem nut	Part 12
Dividing washer	Part 13
Handle	Part 15
Stopper	Part 14
Lock nut	Part 17
Nut	Part 12
Spring washers	Part 11
Gland nut	Part 10

Push the stem to the inside part of the body and remove it. Later, remove the *packaging* (part 9) located inside the body. Remove the *o'ring* (part 8) from its location and also the *friction washer* (part 7).

g.- Once the valve is disassembled you must verify the state of each single piece that composes it. All pieces to be reused have to be completely cleaned and be kept in a safe and clean environment.

All locking surfaces in the ball, seats, joints and sides have to be checked for corrosion, erosion or metallic inlays in the seats and marks. If they were damaged or in case of doubt, they will need to be replaced.

h.- Cleaning of the valve's pieces must be done using an adequate degreasing agent. You must be careful with the locking surfaces, for example, of the ball, locking sides of the cap and joints, because if they were damaged this could cause a bad impact in the valve's performance.

7.2) Reassembling

Before proceeding to reassemble the valve, make sure that reparation kit and/or pieces to be used are appropriate and original from the factory.

When it is assembled again, cleaning is essential for a long life.

a.- Place a new *friction washer* (part 7) on the stem (part 4) and also the *o'ring* (part 8) in its stem corresponding location, lubricate the stem with a thin layer of grease or silicon (for example, Dow Corning 200) and insert it in the valve's *body* (part 1), in the internal cavity, by pushing a bit to fix it.

b.- Place a new packaging (part 9) into its location in the upper cavity of the *body* (part 1), the *gland nut* (part 10) and the *spring washers* (part 11) with external borders together (concave position). Place the *nut* (part 12) and tighten it. Make the stem turn a couple of times and readjust the nut, respecting the torque specified value (See Section 8.2).

If necessary, fasten with a wrench the internal body of the stem to tighten properly the nut without making the stem turn.

It is convenient to match one of the nut vertexes with one of the stem vertex to be able to place later on the lock nut (part 17).

Note that if the nut is too tight, the rod torque will increase and service life of its elements will be reduced.

c.- Place one of the seats (part 5) in the inside part of the body and the other seat in the cap's placement.

d.- Place the stem in closed valve position and insert the *ball* (part 3) inside the *body* (part 1) matching the ball slot with stem milling (part 4).

e.- Place the body joint (part 6) on the stem (part 2).

f.- With the valve in closed position, place the cap in the body and tighten as much as you can.

It is required that the body and cap make contact in their metal sides.

8. Torques table:

8.1) Breakaway torque:

MEASURE	Breakaway torque (N·m)
1/4"	4 – 5
3/8"	4 – 5
1/2"	4 – 5
3/4"	7 – 8
1"	9 – 10
1 1/4"	12 – 14
1 1/2"	18 – 20
2"	28 – 30

8.2) Tightening torque for stem nut:

Following numerical data is provided as reference only. Torques mentioned are the ones used to activate the assembled stem before ball and seats are assembled.

Valve size	Maximum torque (N.m.)
1/4" - 3/8" - 1/2"	6 - 9
3/4" - 1"	8 - 12
1 1/4" - 1 1/2" - 2"	13 - 18

9. Hygiene and Safety Instructions:

9.1) Fluids that go through a valve can be corrosive, toxic, flammable or pollutant. They can also be found at very high or low temperature. When operating valves, you must follow the security instructions and it is recommended to use personal protection gadgets:

- 1) Protect your eyes.
- 2) Wear gloves and appropriate working clothes.
- 3) Wear safety footwear.
- 4) Wear a helmet.
- 5) Have running water at hand.
- 6) To operate flammable fluids, make sure you have an extinguisher at hand.



Before removing a valve from a pipe, always check if the line is completely drained and depressurized.

9.2) Operate the valve in open position to make sure there is no pressure in the internal cavity.

9.3) Any valve being used by toxic services department needs to obtain a cleanliness certificate before being operated.

9.4) Any type of repair or maintenance should be performed in ventilated places.