



Product description

Vertical folding bar
Nylon finished AISI 304 stainless steel
3 mm AISI 304 stainless steel support and hinge
Length: 718 mm.
Supports 120 Kg

Technical specifications:

Vertical folding bar with gradual braking system incorporated. This bar is composed of an AISI 304 stainless steel tubing with 25 mm of diameter and 3 mm of thickness. The tube has been bent as a "U" and has a 5 mm nylon layer finish. The structure turns 90° to the wall supports in order to be able to leave the seat in upright position. The wall support is composed of an AISI 304 stainless steel plate with 3mm of thickness, and two AISI 304 stainless steel hinges with 3 mm of thickness using to turn the folding bar. The finish of the assembled unit and its materials assure a correct maintenance and cleaning. The folding bar is fixed to the wall with 4 screws and 4 nylon wall plugs to support static loads of 120Kg. The folding bar code is GW11 30 09 00, manufactured by GENWEC WASHROOM S.L. - Av. Joan Carles I, 46-48 - c.p: ES- 08908 L'Hospitalet de Llobregat - Barcelona (SPAIN). www.genwec.com.

Technical characteristics

Product specifications

AISI 304 stainless steel tubing with Ø 25 mm and 3 mm of thickness
5 mm nylon layer finish
AISI 304 stainless steel wall support and hinge
Supports 120 Kg if properly fixed

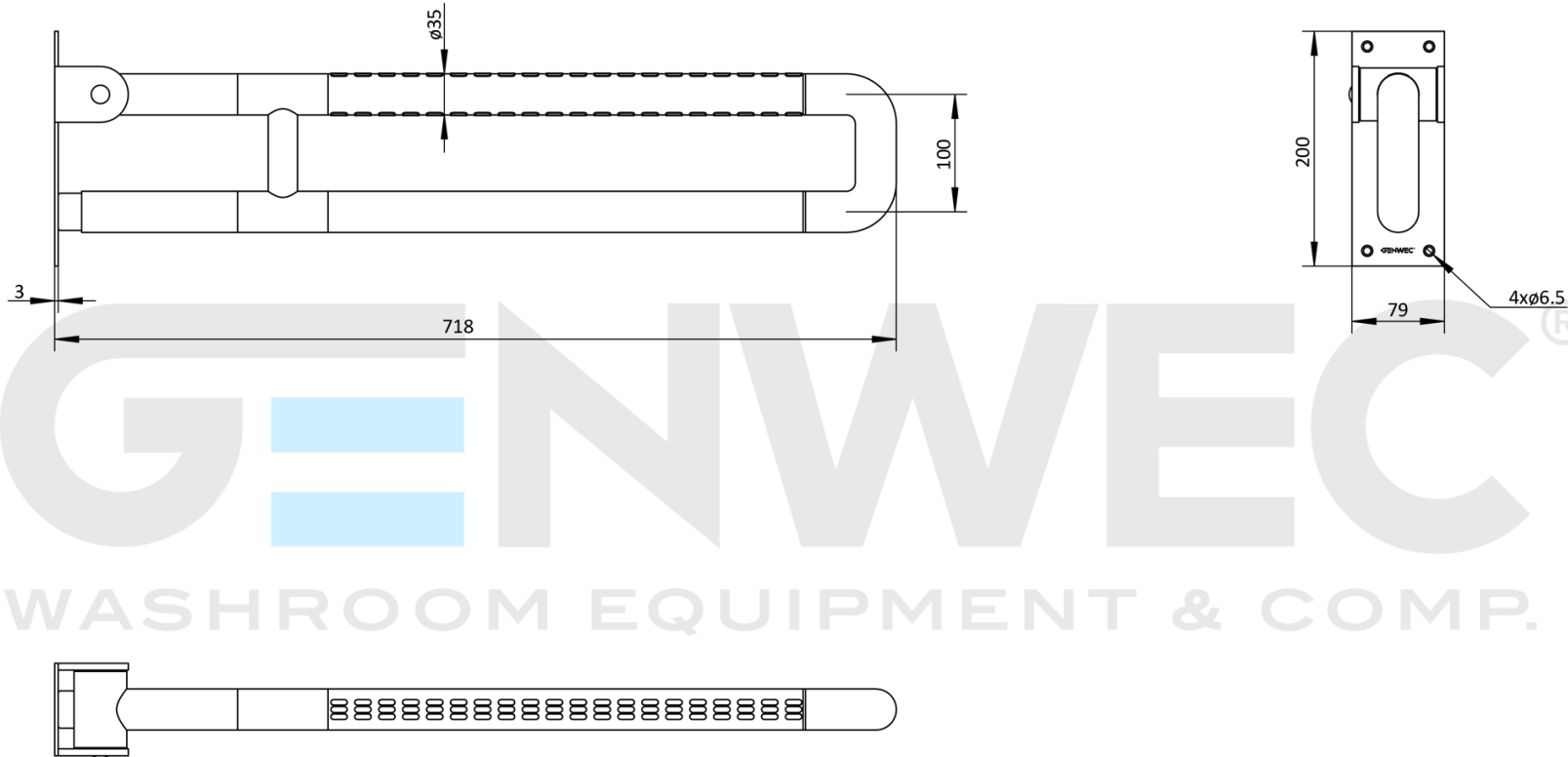

Cleaning: A cotton cloth slightly dampened in a soapy solution is recommended. Then dry off.