

HAND DRYERS **GW01 22 01 04 Model SCREENflow with drain pan**



Product description

Hot air hand dryer
Operates by electronic sensor
Silver finish
Efficient dryer: Minimum consumption/Drying < 15 s.
ON/OFF Resistor
With drain pan for maximum hygiene
3-year warranty

Technical specifications:

The hot air hand dryer consists of a one-piece casing in ABS plastic with a linear air output at the bottom end (curtain type) and a base, also made in ABS plastic, that serves as support for the volute-nozzle made in flame-retardant thermoplastic. The base-casing assembly which makes up the hand dryer is fixed to the wall by means of 4 holes and wall plugs. The drain pan, in ABS plastic, is attached to the base by means of two screws. The dryer is operated by an electronic infra-red sensor and it automatically stops after the hands have been withdrawn from the sensor field. The universal brushed motor, located in the centre of the volute, produces 24,000 r.p.m. The dryer delivers an airflow of 2,833 l/min (170 m³/h) at a speed of 324 km/h. The air flows as long as the user continues to use it. The dryer has a total power rating of 1100W at 230V, with a maximum consumption of 4.5A. The resistor can be switched off using the switch located next to the air output. The noise level at a distance of 2 metres is 68dB. The protection class against splashing is IPX1. The hand dryer model is GW01 22 01 04, manufactured by GENWEC WASHROOM S.L. - Av. Joan Carles I, 46-48 - c.p: 08908 L'Hospitalet de Llobregat - Barcelona. www.genwec.com.

Technical characteristics

Electrical specifications

Voltage/Frequency: 220-240V 50/60 Hz
Maximum intensity: 4.5 A
Total power rating: 1,100 W
Resistor power rating: 550 W
Motor power rating: 550 W
Motor type: Universal, brushed
Rotor speed: 24,000 r.p.m.
Electrical insulation: Class II
Protection class: IPX1
Vandal-proof disconnection after 60 s.
Resistor overheat thermostat.
(Automatic reset)

Mechanical specifications

Air flow: 2,833 l/min (170 m³/h)
Air speed: 324 km/h
Noise level at 2 m: 68 dB
Output air temperature at an ambient T. of 21 °C: 38 °C
Outer casing type: ABS

Packaging specifications

- Type of individual package: Individual cardboard box and bubble wrap.
- Dimensions of individual package: 415 x 295 x 220 mm
- Weight of individual package: 4.25 Kg
- Product dimensions: 520 x 248 x 190 mm
- Product net weight: 3.6 Kg
- Units per box: 4
- Units per pallet: 32 (*)

(*) Height of the pallet below 1.1 m.

HAND DRYERS **GW01 22 01 04 Model SCREENflow with drain pan**

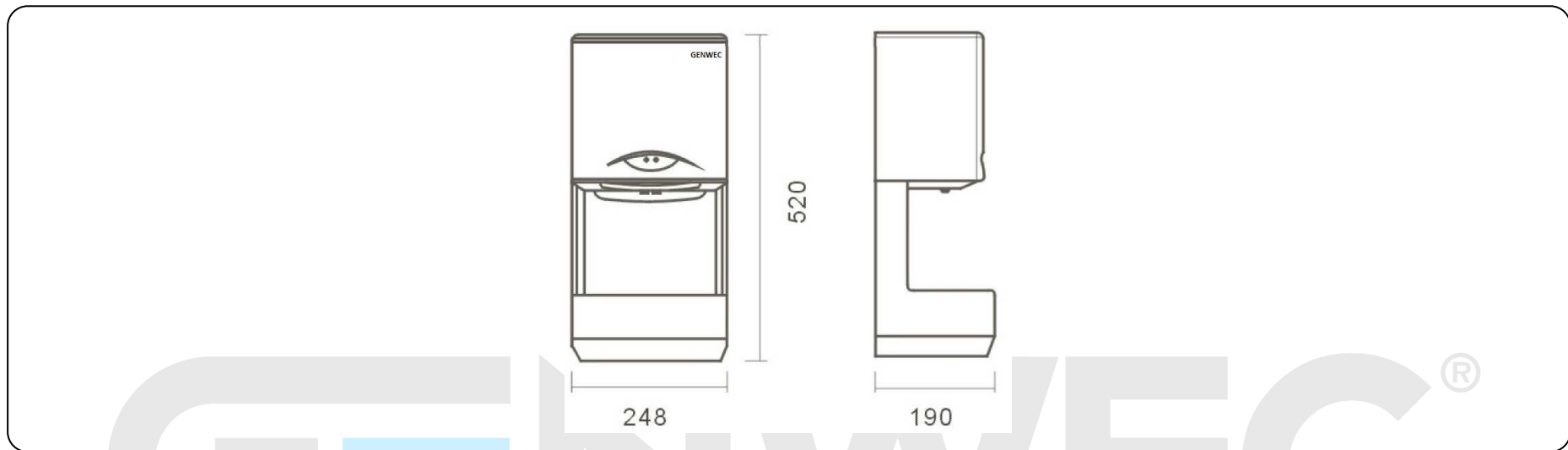

Cleaning: A cotton cloth slightly dampened in a soapy solution is recommended. Then dry off. Do not use any strong chemicals or cleaning agents that can be dangerous to children.

WASHROOM EQUIPMENT & COMP.